

RDP SERIES

130~250W DC/DC CONVERTERS Single Output

並列運転可能
Parallel Operation



H36×W100×L220 (mm)

Features

- Wide Input Voltage Range
- High Efficiency 85%~92%
- Input-Output Isolation (AC2000V)
- Low Output Ripple and Noise
- Possible Parallel Operation up to 4 converters
- Remote ON/OFF Control
- Input Rush Current Protection
- Input Low Voltage Protection
- Input Over Voltage Protection
- Output Over Voltage Protection 120%~140% Operation
- Operating Ambient Temp -25°C~+71°C
- Max. Case Temperature +85°C
- Conformity to RoHS2 Directive
- 広範囲な入力電圧範囲
- 高効率 85%~92%
- 入出力間絶縁 (AC2000V)
- 出力リップル、ノイズが小さい
- 4台まで並列運転可能
- リモートON/OFFコントロール機能
- 入力突入電流保護回路内蔵
- 入力低電圧保護回路内蔵
- 入力過電圧保護回路内蔵
- 出力過電圧保護回路内蔵 120%~140%動作
- 動作周囲温度 -25°C~+71°C
- 最大ケース温度+85°C
- RoHS2指令対応

General Characteristics

- Input Voltage, Range (at Ta : 25°C, Full Load, Nominal Vin) DC 12, 24, 48, 96V (See Table 1)
- Output Voltage, Current See Table 1
- Output Voltage Adjustment -3~+10%
- Efficiency See Table 1
- Line Regulation 0.2% max. (at Vin Range)
- Load Regulation ±1.5% typ. (0~100% Load) (See Fig. 8)
- Output Ripple (0.1% Vout+50mV) p-p max.
- Output Noise (0.5% Vout+50mV) p-p max.
- Short Circuit Protection Built-in, Auto-restart (See Fig. 2)
- Output Over Voltage Protection Built-in, Shut-down (120%~140% Vout)
- Remote ON/OFF Control ON : Short or 0~0.8V
OFF : Open or 2~10V (Between terminal ③ ~ ④)
- Temperature Coefficient 0.02%/°C max.
- Operating Ambient Temp. -25°C~+71°C (See Fig. 1)
- Max. Case Temp. +85°C
- Storage Temp. -40°C~+85°C
- Isolation Voltage AC2000V one minute (Input-Output-Case)
- Isolation Impedance 100MΩ min. (at DC1000V) (Input-Output-Case)
- Weight Main Body : 1.8kg max.
Heat Sink : 400g max.
- Humidity 20~95% RH
- Shock 490m/s² (11msec 3directions)
- Vibration JIS E4031 Category 1 - Class B
- Surface Structure Aluminum Case
- MTBF 100,000H (Ta : 25°C, 80% Load, Nominal Vin)
- Warranty 5 years

Terminal Outs & Dimensions (±0.5mm)

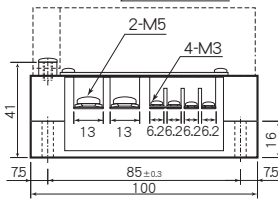
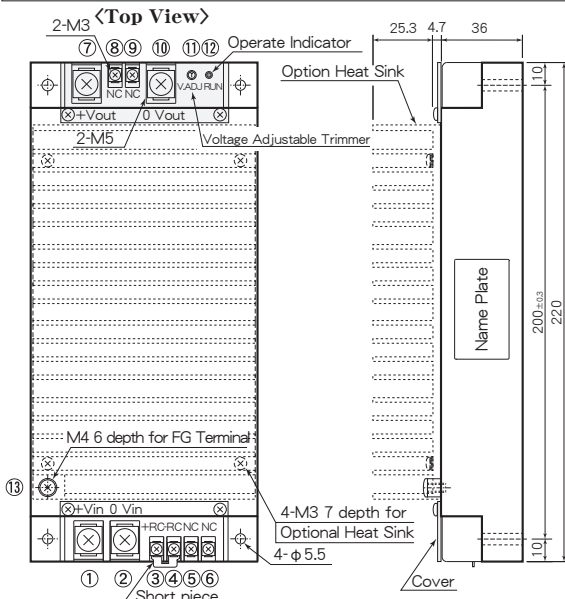

Terminal Outs and Function

| | |
|------------|---------------------|
| ① +Vdc in | ⑦ +Vdc out |
| ② 0 Vdc in | ⑧ NC |
| ③ +RC | ⑨ NC |
| ④ -RC | ⑩ 0 Vdc out |
| ⑤ NC | ⑪ V.ADJ |
| ⑥ NC | ⑫ Operate Indicator |
| | ⑬ FG |

* Option Heat Sink Model : A3-9023

Selection Guide

Table 1

| Model Number | Input Voltage (Range) (V. DC) | Input Rush Current (max.)(A) | Output Voltage (V. DC) | Output Current (A) | Efficiency (typ.) (%) | |
|---------------------|-------------------------------|------------------------------|------------------------|--------------------|-----------------------|----------|
| | | | | | 20% Load | 80% Load |
| RDP12 - 3.3S 40A | 12 (9~18) | 62 | 3.3 | 40 | 85 | 85 |
| RDP12 - 5S 40A | | | 5 | 40 | 86 | 87 |
| RDP12 - 12S 20.8A | | | 12 | 20.8 | 88 | 89 |
| RDP12 - 13.8S 18.1A | | | 13.8 | 18.1 | 88 | 89 |
| RDP12 - 15S 16.7A | | | 15 | 16.7 | 88 | 89 |
| RDP12 - 24S 10.5A | | | 24 | 10.5 | 89 | 89 |
| RDP12 - 48S 5.3A | | | 48 | 5.3 | 89 | 90 |
| RDP12 - 100S 2.5A | | | 100 | 2.5 | 89 | 90 |
| RDP12 - 140S 1.8A | | | 140 | 1.8 | 89 | 89 |
| RDP12 - 200S 1.3A | | | 200 | 1.3 | 89 | 90 |
| RDP12 - 300S 0.85A | | | 300 | 0.85 | 89 | 90 |
| RDP24 - 3.3S 40A | | | 24 (18~36) | 31 | 3.3 | 40 |
| RDP24 - 5S 40A | 5 | 40 | | | 87 | 88 |
| RDP24 - 12S 20.8A | 12 | 20.8 | | | 88 | 91 |
| RDP24 - 13.8S 18.1A | 13.8 | 18.1 | | | 88 | 91 |
| RDP24 - 15S 16.7A | 15 | 16.7 | | | 88 | 90 |
| RDP24 - 24S 10.5A | 24 | 10.5 | | | 88 | 91 |
| RDP24 - 48S 5.3A | 48 | 5.3 | | | 89 | 91 |
| RDP24 - 100S 2.5A | 100 | 2.5 | | | 89 | 92 |
| RDP24 - 140S 1.8A | 140 | 1.8 | | | 90 | 91 |
| RDP24 - 200S 1.3A | 200 | 1.3 | | | 90 | 91 |
| RDP24 - 300S 0.85A | 300 | 0.85 | | | 91 | 92 |
| RDP48 - 3.3S 40A | 48 (36~72) | 16 | | | 3.3 | 40 |
| RDP48 - 5S 40A | | | 5 | 40 | 88 | 90 |
| RDP48 - 12S 20.8A | | | 12 | 20.8 | 88 | 91 |
| RDP48 - 13.8S 18.1A | | | 13.8 | 18.1 | 88 | 91 |
| RDP48 - 15S 16.7A | | | 15 | 16.7 | 88 | 91 |
| RDP48 - 24S 10.5A | | | 24 | 10.5 | 88 | 91 |
| RDP48 - 48S 5.3A | | | 48 | 5.3 | 89 | 91 |
| RDP48 - 100S 2.5A | | | 100 | 2.5 | 89 | 91 |
| RDP48 - 140S 1.8A | | | 140 | 1.8 | 89 | 91 |
| RDP48 - 200S 1.3A | | | 200 | 1.3 | 89 | 91 |
| RDP48 - 300S 0.85A | | | 300 | 0.85 | 89 | 91 |
| RDP96 - 3.3S 40A | | | 96 (70~144) | 8 | 3.3 | 40 |
| RDP96 - 5S 40A | 5 | 40 | | | 88 | 90 |
| RDP96 - 12S 20.8A | 12 | 20.8 | | | 88 | 91 |
| RDP96 - 13.8S 18.1A | 13.8 | 18.1 | | | 88 | 91 |
| RDP96 - 15S 16.7A | 15 | 16.7 | | | 88 | 91 |
| RDP96 - 24S 10.5A | 24 | 10.5 | | | 88 | 92 |
| RDP96 - 48S 5.3A | 48 | 5.3 | | | 88 | 92 |
| RDP96 - 100S 2.5A | 100 | 2.5 | | | 88 | 92 |
| RDP96 - 140S 1.8A | 140 | 1.8 | | | 89 | 91 |
| RDP96 - 200S 1.3A | 200 | 1.3 | | | 89 | 91 |
| RDP96 - 300S 0.85A | 300 | 0.85 | | | 89 | 91 |

* 上記仕様以外にも対応可能ですので お問い合わせ下さい。
Please consult with us about other specification.

RDP SERIES DATA SHEET

Block Diagram

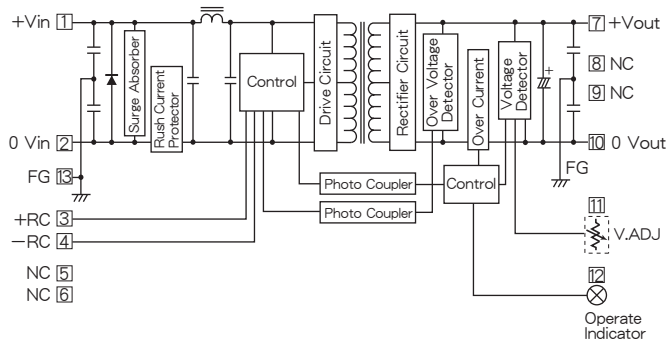

Characteristic Curves

Fig. 1 Derating Curve

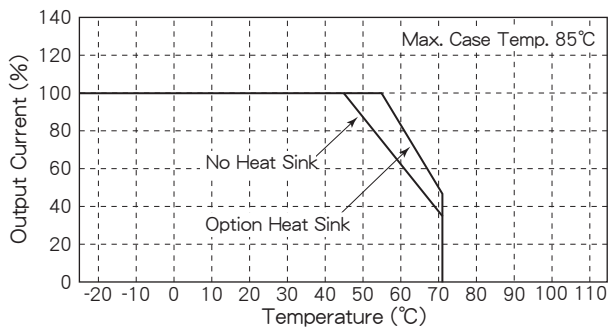

Fig. 2 Short Circuit Operating Area

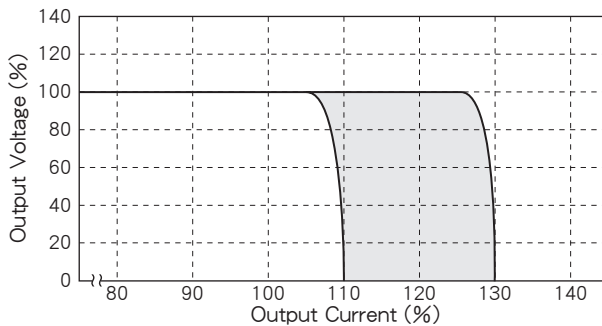

Fig. 3 Temperature Characteristic on Case Surface

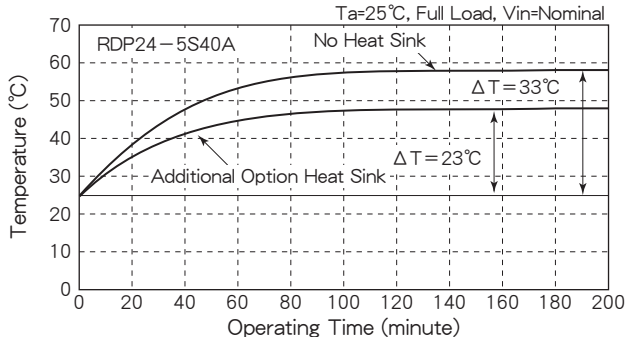

Fig. 4 Efficiency vs. Output Current

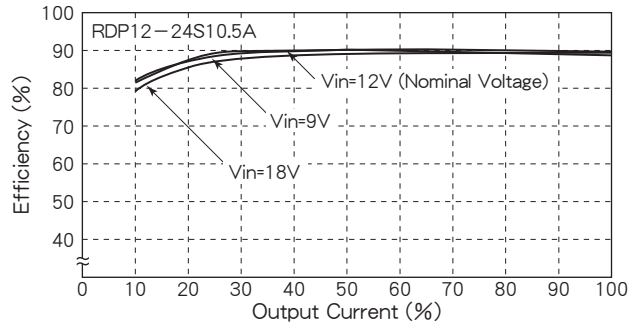

Fig. 5 Efficiency vs. Output Current

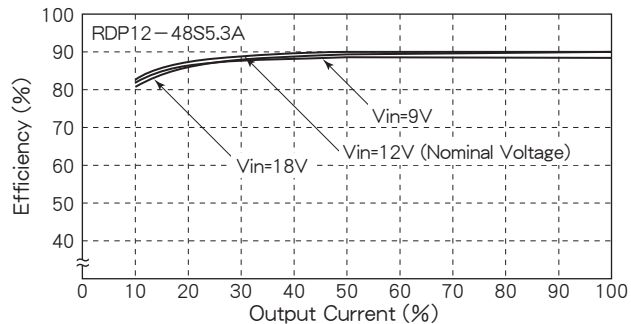

Fig. 6 Efficiency vs. Output Current

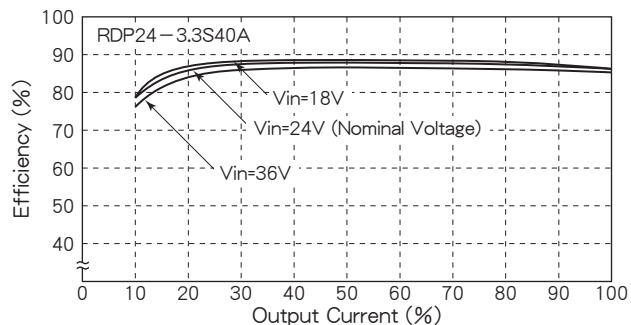

Fig. 7 Efficiency vs. Output Current

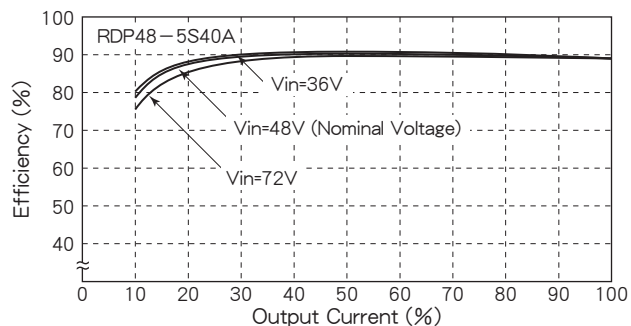
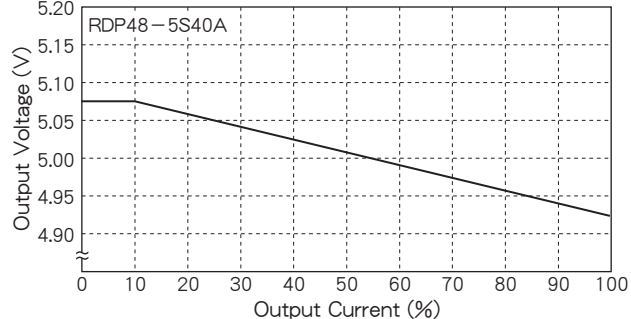

Fig. 8 Output Voltage vs. Output Current



* 並列運転時に各モジュールの電流を平均化するため 負荷変動を大きくしてあります。

Load Regulation is regulated large on purpose to equate the each unit's output current at parallel operation.

RDP SERIES DATA SHEET

■ 主な機能及び注意事項 Function and direction in application

1. 入力低電圧保護、入力過電圧保護 Input low/over voltage protection
 下記入力電圧にて出力電圧がOFFとなります。入力電圧を規定値内に戻すと自動復帰します。
 Output will be shut down in the input voltages on the following table. Output will automatically be reset when the input voltage comes to within the specified value.

| 定格入力電圧 Rated input voltage | 低電圧保護 Low voltage protection | 過電圧保護 Over voltage protection |
|-------------------------------|---------------------------------|----------------------------------|
| 12V (9~18V) | 6~8V | 20~22V |
| 24V (18~36V) | 12~16V | 40~44V |
| 48V (36~72V) | 24~32V | 75~82V |
| 96V (70~144V) | 48~64V | 150~165V |

2. 出力電圧値 Output voltage
 出力電圧値はボリューム(V.ADJ)を回転させることにより、定格出力電圧の約-3%~+10%可変することができます。
 Output voltage will be adjusted to -3% - +10% of rated voltage by means of volume (V.ADJ).

3. 出力過電流保護 Output over current protection
 負荷が短絡した場合など、過大な負荷電流が流れたときに負荷と本体を保護する機能です。定格出力電流の約110%~130%にて検出し作動します(Fig. 2 参照)。出力は定電流電圧垂下特性、入力電流はフの字特性となっています。また自動復帰特性を有しています。
 This function is to protect a power supply and a load when excessive current flows in case of short-circuited load or such possible conditions. It will operate in 110 - 130% of rated output current (see Fig. 2). Output has constant current voltage limiting characteristic and input current has combined current limiting with fold-back protection. It also has automatic reset function.

4. 出力過電圧保護 Output over voltage protection
 出力の過電圧から負荷側を保護する機能です。出力電圧値が定格値の約120~140%になると出力をOFFします。
 This function is to protect a load from output over voltage. Output will be shut down when output voltage is 120 - 140% of rated voltage.

5. リモートON/OFFコントロール Remote ON/OFF control
 リモートON/OFFコントロールを使用して、電源の出力をON/OFFすることができます。RC端子間をショートする事で出力電圧がON、RC端子間をオープンにする事で出力電圧がOFFになります。RC端子間にTTLレベルの電気信号を加える事により出力をON/OFFすることができます。RC端子は入力側にあり、入力電源回路とは絶縁されていません。ON/OFFコントロールを使用しないときは、+RC端子と-RC端子を付属のショートピンで短絡させて下さい。
 Using remote ON/OFF control, ON/OFF of the power supply output is possible. The output voltage operates by a short between RC terminals, and the output voltage stops by open between RC terminals. ON/OFF of the output voltage is possible by adding the electrical signal of the TTL level between RC terminals. RC terminals are located on the input side and the circuit is not isolated from input power source circuit. In case you don't use ON/OFF control, please short-circuit +RC and -RC terminals by means of attached short-bar.

* 回路構成例 Example of ON/OFF control circuit

●TRIによる例 Example by transistor ●SWによる例 Example by switch

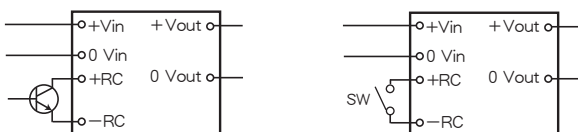

6. 並列運転 Parallel operation
 同機種を並列に動作させることにより出力電流量を増やすことができます。並列運転は4台まで接続可能です。
 It is possible to increase output current capacity by means of parallel operation of the same model. Please see the figure below for wiring instructions. Parallel operation is possible up to 4 converters.

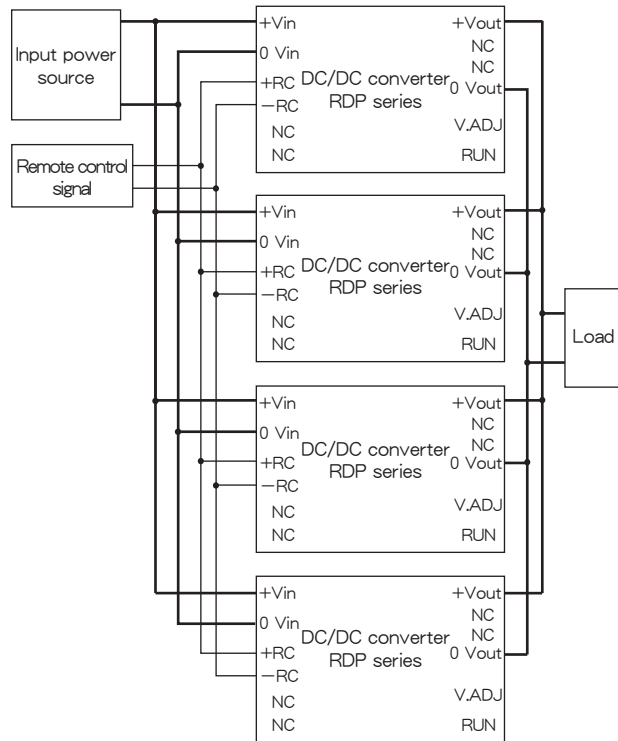

7. 入力側ヒューズ Input side fuse
 電源の破損に備えて、必ず入力側にヒューズ又はブレーカーを使用してください。電流量は表1の突入電流値を参考にしてください。
 Please insert a fuse or a circuit breaker to prevent possible damage of converter. Please refer to Table 1 (rush current) to select proper current capacity of fuse or circuit breaker.

RDP SERIES DATA SHEET