

BPU SERIES

20~50W DC/DC CONVERTERS Single Output & Dual Outputs

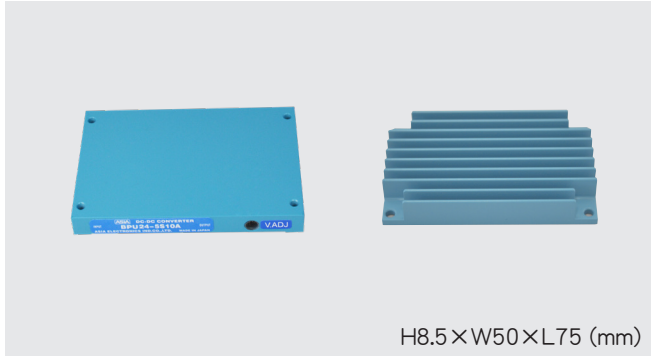

H8.5×W50×L75 (mm)

Features

- Low Profile 8.5mm
 - 6 Sided Metal Shielding
 - Built-in Input Filter
 - Wide Input Voltage Range
 - Input-Output Isolation
 - Adjustable Output Volt. $\pm 5\%$
 - High Efficiency 81~90%
 - Remote ON/OFF Control
 - Input Low Voltage Protection
 - Input Over Voltage Protection
 - Output Over Voltage Protection 115~140% Operation
 - Thermal Protection +110°C~+120°C
 - Operating Ambient Temperature -40°C~+85°C
 - Max. Case Temperature +105°C
 - High Reliability
 - Conformity to RoHS2 Directive
 - Not built-in aluminum and tantalum electrolytic capacitor
- 薄型 8.5mm
 - 6面メタルシールド
 - 入力フィルタ内蔵
 - 広範囲な入力電圧
 - 入出力間絶縁
 - 可変出力電圧 $\pm 5\%$
 - 高効率 81~90%
 - リモートON/OFFコントロール
 - 入力低電圧保護回路内蔵
 - 入力過電圧保護回路内蔵
 - 出力過電圧保護回路内蔵 115~140% 動作
 - 過熱保護回路内蔵 +110°C~+120°C
 - 動作周囲温度 -40°C~+85°C
 - 最大ケース温度 +105°C
 - 高信頼性
 - RoHS2指令対応
 - アルミ電解コンデンサ及びタンタルコンデンサ不使用

General Characteristics

(at T_a : 25°C, Full Load, Nominal V_{in})

- Input Voltage, Range DC12, 24, 48, 100V (See Table 1)
- Output Voltage, Current See Table 1
- Output Voltage Range $\pm 5\%$ Adjustable
- Efficiency See Table 1
- Line Regulation $\pm 0.3\%$ max. (at V_{in} Range)
- Load Regulation Single : $\pm 0.5\%$ max. (0~100% Load)
Dual : $\pm 3\%$ max. (10~100% Load)
- Reflected Input Ripple, Noise (3% V_{in})/Vp-p max.
- Output Ripple 40mVp-p max.
- Output Noise 100mVp-p max.
- Short Circuit Protection Built-in, Auto-restart (See Fig. 2)
- Over Voltage Protection 115~140% Output Voltage
- Remote ON/OFF Control ON : Short or 0~0.8V
OFF : Open or 2~10V (Between pin ③ ~ ②)
- Temperature Coefficient 0.02%/°C max.
- Operating Ambient Temp. -40°C~+85°C (See Fig. 1)
- Max. Case Temperature +105°C
- Storage Temperature -40°C~+115°C
- Isolation Voltage AC1500V 1 min.
AC2000V 1 min. (100V V_{in} only)
(Input-Output-Case)
100M Ω min. (at DC1000V)
(Input-Output-Case)
- Isolation Impedance
- Weight Main Body : 100g max.
Heat Sink : 55g max.
- Humidity 20~95% RH
- Shock 490m/s² (11msec 3directions)
- Vibration 10~55Hz 98m/s² (30minutes 3directions)
- Surface Structure 6 Sided Aluminum Case
- Soldering Conditions 260°C, for 15 seconds max.
Soldering DIP 360°C, for 5 seconds max.
Soldering iron
- MTBF Single : 600,000H
Dual : 600,000H
(T_a : 25°C, 80% Load, Nominal V_{in})
- Warranty 5 years

Pin Outs & Dimensions (± 0.5 mm)

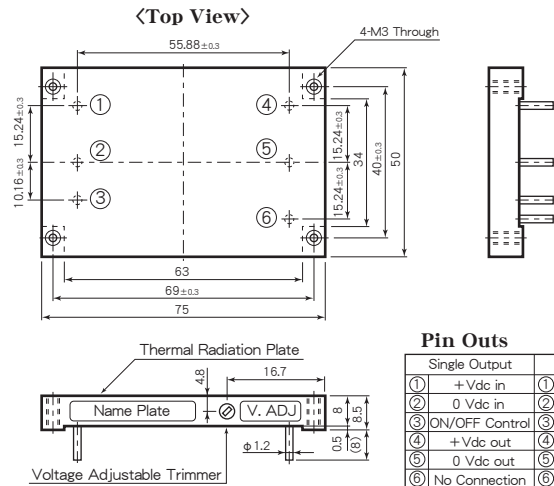

Holes on PCB (Top View)

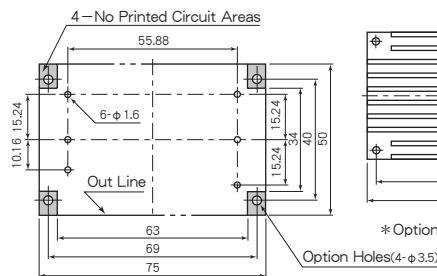

Option Heat Sink

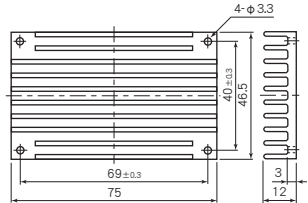

Selection Guide

Table 1

Model Number	Input Voltage (Range) (V. DC)	Output Voltage (V. DC)	Output Current (A)	Efficiency (typ.) (%)		
				30% Load	80% Load	
BPU12-33S12A	12 (8~18)	3.3	12	87	85	
BPU12-5S10A		5	10	86	89	
BPU12-6S8.4A		6	8.4	87	87	
BPU12-12S4.2A		12	4.2	84	88	
BPU12-15S3.3A		15	3.3	83	88	
BPU12-24S2.1A		24	2.1	83	88	
BPU12-33S1A		33	1	80	81	
BPU12-50S0.6A		50	0.6	80	82	
BPU12-12D1.5A		12	1.5	81	83	
BPU12-15D1.2A		15	1.2	81	84	
BPU24-33S12A		24 (16~36)	3.3	12	84	85
BPU24-5S10A			5	10	85	88
BPU24-6S8.4A	6		8.4	87	89	
BPU24-12S4.2A	12		4.2	84	89	
BPU24-15S3.3A	15		3.3	85	89	
BPU24-24S2.1A	24		2.1	84	89	
BPU24-33S1A	33		1	80	81	
BPU24-50S0.6A	50		0.6	80	82	
BPU24-12D1.5A	12		1.5	81	84	
BPU24-15D1.2A	15		1.2	82	85	
BPU48-33S12A	48 (32~72)		3.3	12	85	86
BPU48-5S10A			5	10	85	88
BPU48-6S8.4A		6	8.4	85	88	
BPU48-12S4.2A		12	4.2	85	90	
BPU48-15S3.3A		15	3.3	85	90	
BPU48-24S2.1A		24	2.1	85	90	
BPU48-33S1A		33	1	80	81	
BPU48-50S0.6A		50	0.6	80	82	
BPU48-12D1.5A		12	1.5	81	84	
BPU48-15D1.2A		15	1.2	82	85	
BPU100-33S12A		100 (64~144)	3.3	12	84	87
BPU100-5S10A			5	10	86	89
BPU100-6S8.4A	6		8.4	84	89	
BPU100-12S4.2A	12		4.2	85	90	
BPU100-15S3.3A	15		3.3	85	90	
BPU100-24S2.1A	24		2.1	85	90	
BPU100-33S1A	33		1	80	81	
BPU100-50S0.6A	50		0.6	80	82	
BPU100-12D1.5A	12		1.5	81	84	
BPU100-15D1.2A	15		1.2	82	85	

* 上記仕様以外にも対応可能ですので お問い合わせ下さい。
Please consult with us about other specification.

BPU SERIES DATA SHEET

Block Diagram

Single Output

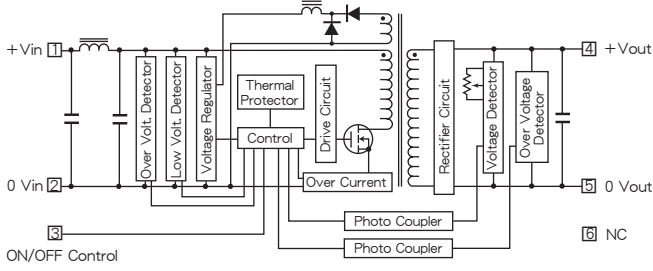

Dual Outputs

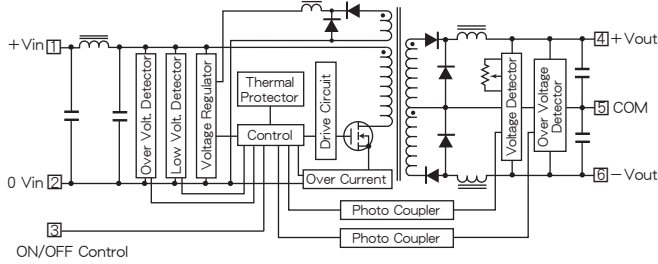

Characteristic Curves

Fig. 1 Derating Curve

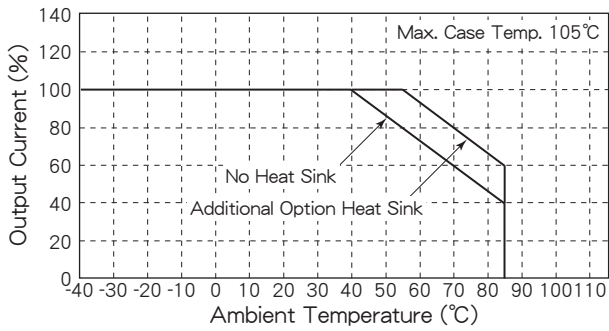

Fig. 2 Short Circuit Operating Area

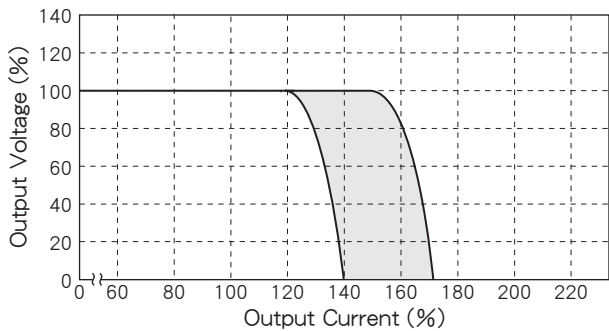

Fig. 3 Temperature Characteristic on Case Surface

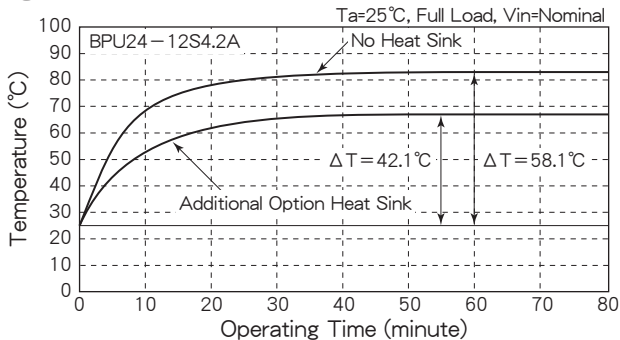

Fig. 4 Efficiency vs. Output Current

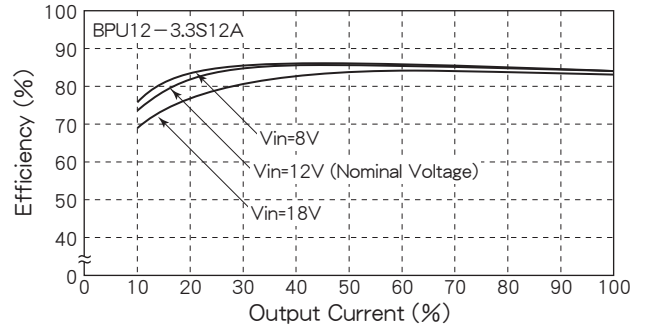

Fig. 5 Efficiency vs. Output Current

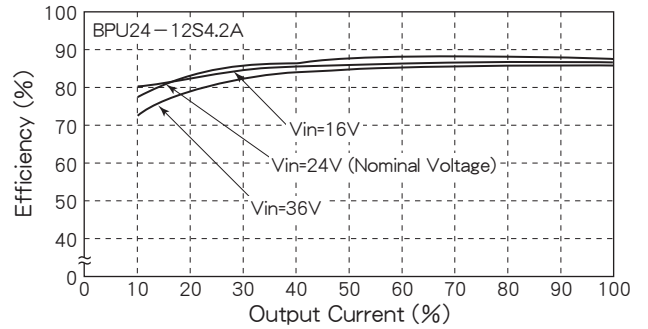

Fig. 6 Efficiency vs. Output Current

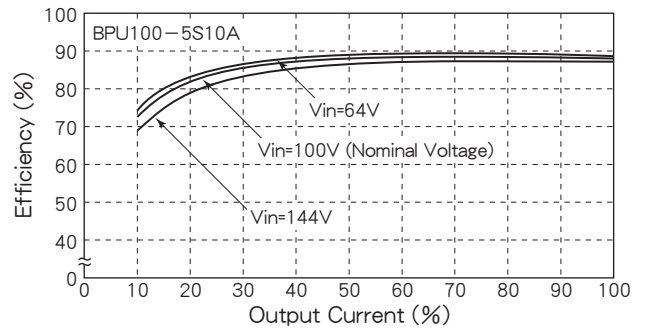

Fig. 7 Efficiency vs. Output Current

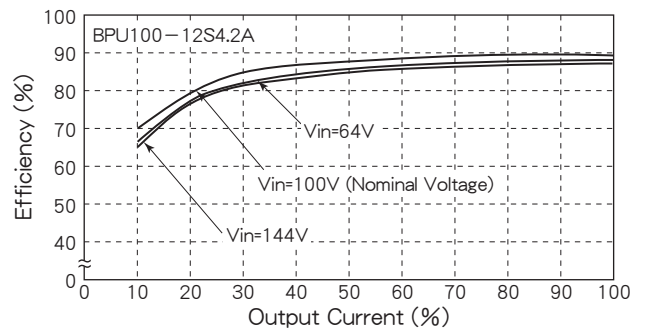

Fig. 8 Efficiency vs. Output Current

